



Steel Bushed Chains

Union Steel Bushed Chains are specially designed and manufactured to provide excellent service in severe working conditions. Our chains are manufactured to close tolerances with the most modern equipment in the industry.

Each component is made from high-quality steels and then specially heat-treated to provide maximum performance and long wear life. Joint parts are hardened to provide greater strength and wear resistance. Sidebars are hardened to achieve ultra-high strength throughout.

Specify Union Steel Bushed Chains when the system operates under gritty or abrasive conditions, such as bucket elevators and other challenging conveyor applications. Union Steel Bushed Chains are also used to replace combination chains when installations are modified to handle heavier loads or operating conditions become more severe.

Steel Bushed Chain Components

Strong, Tough Pins

Pins are made of select alloy steel or high-quality carbon steel. They are hardened to achieve superior strength and extend wear life. This creates the ideal combination of surface hardness for wear resistance and core toughness to resist impact.



Long-Wearing Bushings

Bushings are manufactured to rigid specifications for optimum wear resistance and strength. Select steels are precision machined to maintain consistently high sidebar interference. This results in positive sidebar hold and favorable residual stress to resist fatigue. Bushings are case-hardened and heat-treated to extend the wear life.

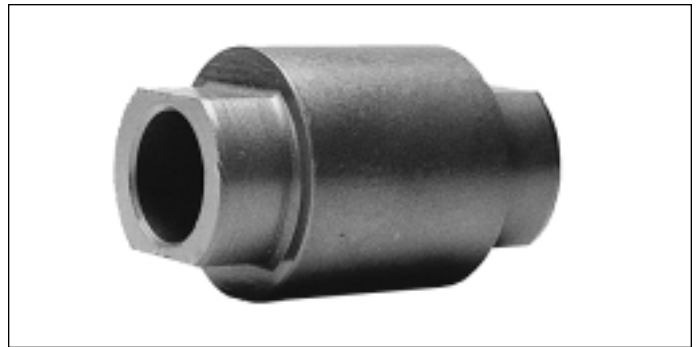

Fatigue-Resistant Sidebars

Sidebars are through-hardened to achieve ultra-high strength. This keeps the chain hanging failure-free, ensuring consistent service life. Union has developed superior techniques to ensure hole quality and pitch control. The result is fatigue resistance and premium performance.



Steel Bushed Plain Chain

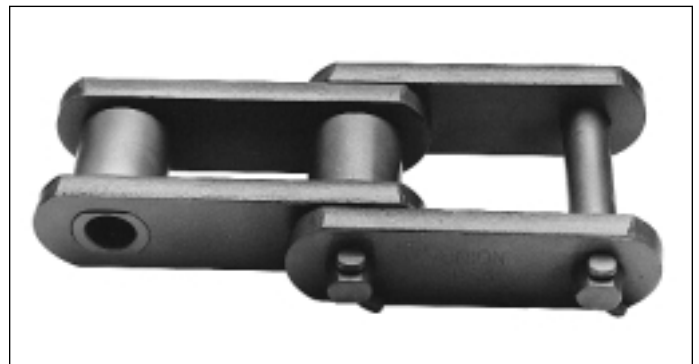
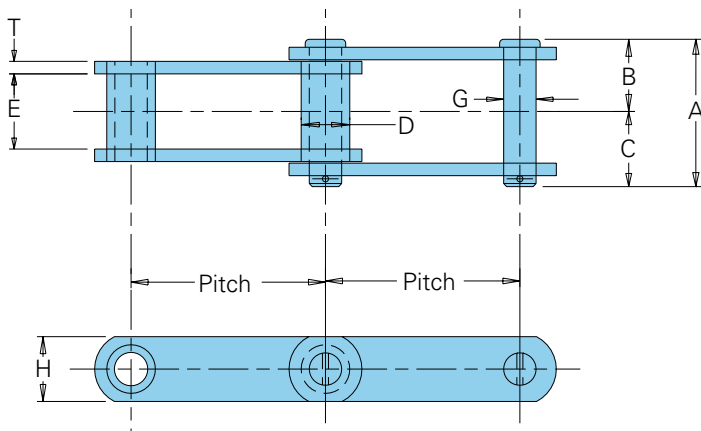

Steel Bushed Plain Chain Specifications

All dimensions are in inches unless otherwise indicated.

Chain Number	Pitch	Width				Bushing			Pin			Sidebar			Average Ultimate Strength (lbs.)	Max. Work Load (lbs.)	Approx. Wgt. (lbs./ft.)
		Overall	Pin Head to CL	Pin End to CL	Inside	Dia.	Sty. ¹	Matl. ²	Dia.	Sty. ³	Matl. ²	Height	Thick.	Matl. ²			
		A	B	C	E	D			G			H	T				
188	2.609	2.69	1.25	1.44	1.06	.88	P	CCH	.50	A	CHT	1.13	.25	CHT	25,000	2,750	3.8
131	3.075	3.53	1.66	1.88	1.31	1.25	P	CCH	.63	A	CHT	1.50	.38	CHT	40,000	4,500	7.5
102B	4.000	4.31	2.03	2.28	2.13	1.00	P	ACH	.63	A	ACH	1.50	.38	CHT	40,000	6,300	6.9
102-1/2	4.040	4.75	2.25	2.50	2.25	1.38	P	CCH	.75	A	ACH	1.75	.38	CHT	50,000	8,850	9.4
111	4.760	5.06	2.38	2.69	2.63	1.44	P	CCH	.75	A	ACH	2.00	.38	CHT	50,000	8,850	10.2
111SP	4.760	5.06	2.38	2.69	2.63	1.44	P	CCH	.75	A	ACH	2.00	.38	CHT	50,000	8,850	8.8
110	6.000	4.31	2.03	2.28	2.13	1.25	P	CCH	.63	A	ACH	1.50	.38	CHT	40,000	6,300	6.3
4856	6.000	6.13	2.88	3.22	3.00	1.75	R	ACH	1.00	K	AHTIH	2.50	.50	AHT	145,000	14,000	16.5
4857	6.000	6.13	2.88	3.22	3.00	1.75	R	ACH	1.00	K	AHTIH	3.25	.50	AHT	175,000	14,000	21.0
4859	6.000	7.38	3.56	3.81	3.75	2.38	R	ACH	1.25	K	AHTIH	4.00	.63	AHT	275,000	21,800	34.0
150X	6.050	6.41	3.03	3.38	3.31	1.75	P	ACH	1.00	A	ACH	2.50	.50	CHT	100,000	15,100	16.6
4864	7.000	7.38	3.56	3.81	3.75	2.38	R	ACH	1.25	K	AHTIH	4.00	.63	AHT	275,000	21,800	31.0

¹Bushing style: P = Double-flat; R = Full-round.

²Material: CHT = Carbon heat-treated; CCH = Carbon case hardened; AHT = Alloy heat-treated; ACH = Alloy case-hardened; AHTIH = Alloy heat-treated induction hardened.

³Pin style: K = Full round; A = Double flat.

To locate compatible sprockets for your chain, refer to the Product Cross-Reference in Section D.

Note: Dimensions are subject to change. Contact Union Chain to obtain certified prints for design and construction.

A-1 Attachment

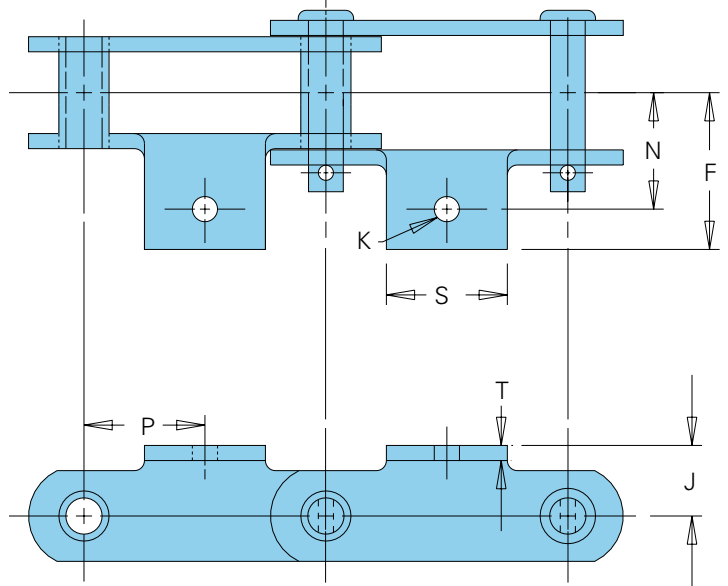

A-2 Attachment

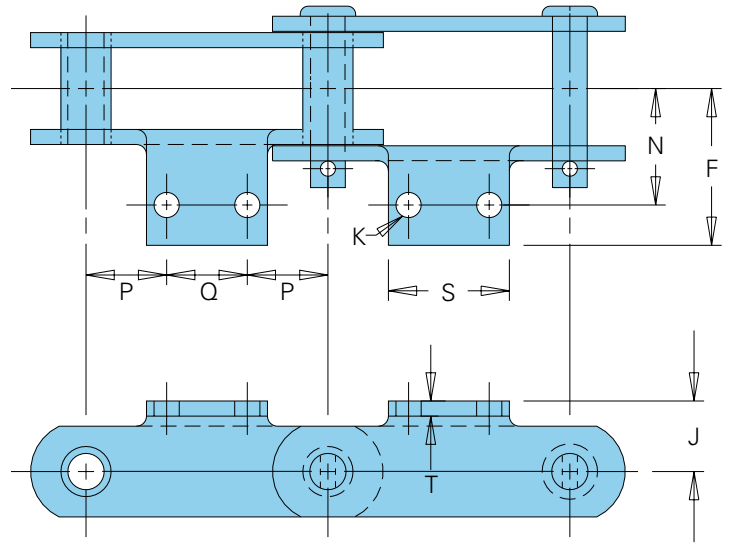

A-22 and A-42 Attachment

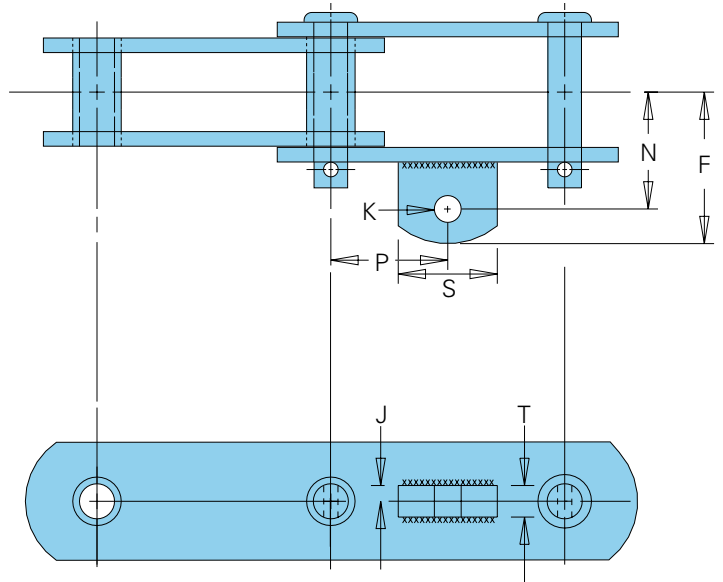

Steel Bushed Attachment Specifications

All dimensions are in inches unless otherwise indicated.

Attach. Number	Chain Number	N	Q	J	S	F	P	Bolt Diameter	K	T	Approx. Weight (lbs./ft.)
A-1	188	1.88		.81	2.13	2.61	1.30	.38		.25	4.8
	131	2.06		1.00	1.31	3.02	1.54	.50		.38	8.9
	102B	2.38		1.00	2.81	3.34	2.00	.38		.38	8.9
	111	3.13		1.50	3.63	3.75	2.38	.50		.38	12.7
	110	2.66		1.00	2.81	3.53	3.00	.38		.38	8.6
A-2	188	2.09	1.25	.81	2.13	2.61	.68	.31		.25	4.8
	131	2.06	1.50	1.13	2.88	2.91	.78	.50		.38	8.9
	102B	2.66	1.75	1.00	2.81	3.34	1.13	.38		.38	8.0
	111	3.13	2.31	1.50	3.63	4.13	1.22	.38		.38	12.4
	110	2.66	1.75	1.00	2.89	3.32	2.13	.38		.38	7.5
A-22 & A-42	188	1.78		.19	1.25	2.38	1.19	.38		.38	4.8
	131	2.63		.16	1.25	3.50	1.53	.38		.38	8.4
	102B	3.13	1.75	.16	1.25	3.88	2.00	.38		.31	7.8
	111	3.38		.19	1.25	4.13	2.38	.50		.38	10.8
	110	3.13		.19	2.00	4.13	3.00	.50		.38	7.1

To locate compatible sprockets for your chain, refer to the Product Cross-Reference in Section D.

Note: Dimensions are subject to change. Contact Union Chain to obtain certified prints for design and construction.



UNION CHAIN DIVISION - STEEL BUSHED CHAINS

U.S. TSUBAKI

A - ENGINEERING CLASS CHAINS

K-1 Attachment

K-2 and K-22 Attachment

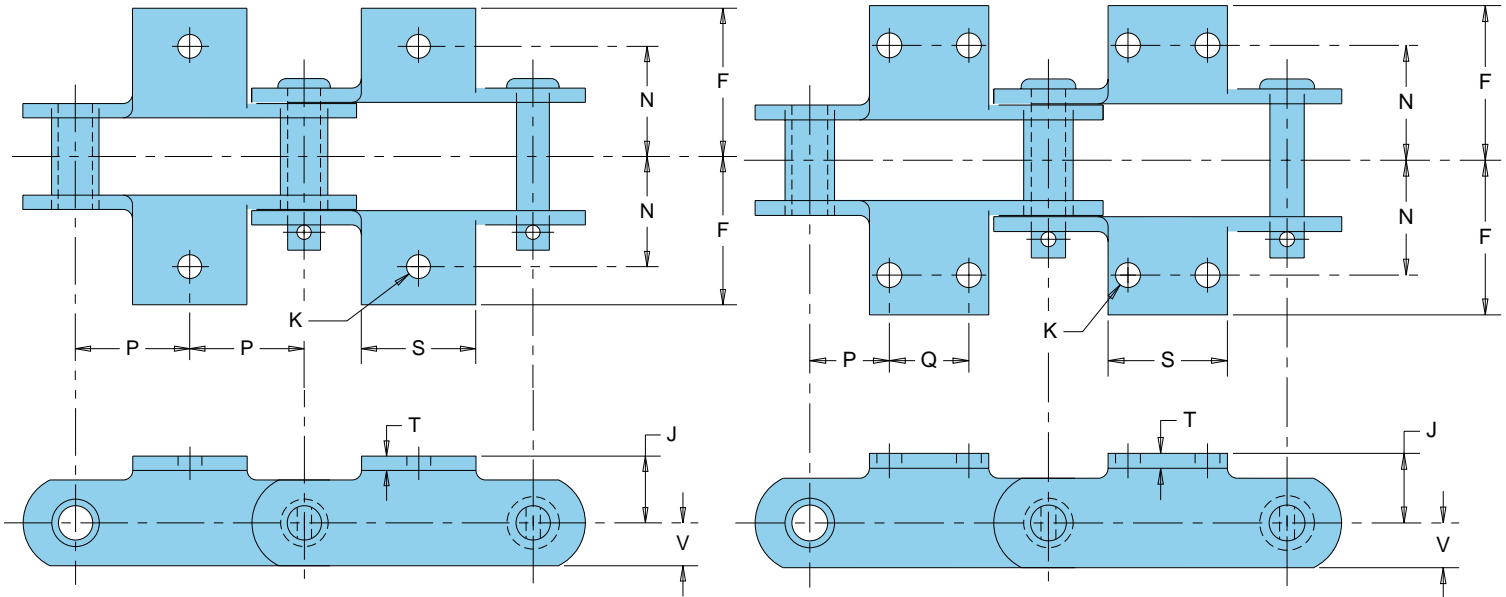

Steel Bushed Attachment Specifications (Continued)

All dimensions are in inches unless otherwise indicated.

Attach. Number	Chain Number	N	M	R	F	L	Q	S	P	Bolt Dia.	K	J	T	V	Approx. Weight (lbs./ft.)
K-1	188	1.88			2.61			2.13	1.30	.38	.81	.25	.56	5.8	
	131	2.06			3.02			1.31	1.54	.50	1.00	.38	.75	10.2	
	102B	2.38			3.34			2.81	2.00	.38	1.00	.38	.75	9.0	
	111	3.13			3.75			3.63	2.38	.50	1.50	.38	1.00	15.2	
K-2	188	2.09			2.61		1.25	2.13	.68	.31	.81	.25	.56	5.8	
	131	2.06			2.91		1.50	2.88	.78	.50	1.13	.38	.75	10.2	
	102B	2.66			3.34		1.75	2.81	1.13	.38	1.00	.38	.75	9.0	
	110	2.66			3.32		1.75	2.88	2.13	.38	1.00	.38	.75	8.6	
	111	3.13			4.13		2.31	3.63	1.22	.50	1.50	.38	1.00	15.2	
	111SP	3.13			4.13		2.31	3.63	1.22	.50	1.50	.38	1.00	15.2	
	150X	3.75			4.91		2.75	4.25	1.66	.50	1.88	.50	1.25	23.0	
4856	3.31			4.41		2.25	4.25	1.88	.50	1.88	.50	1.25	23.0		
K-22	102-1/2	2.66			3.27		1.75	3.13	1.16	.50	1.13	.38	.88	24.0	
	111	3.13			4.13		2.31	3.63	1.23	.38	1.50	.38	1.00	15.2	
	4856	3.16			4.25		2.25	4.25	1.88	.63	1.88	.50	1.25	23.0	

■ Indicates this chain is normally stocked. All others are made-to-order.

To locate compatible sprockets for your chain, refer to the Product Cross-Reference in Section D.

Note: Dimensions are subject to change. Contact Union Chain to obtain certified prints for design and construction.

K-24 Attachment

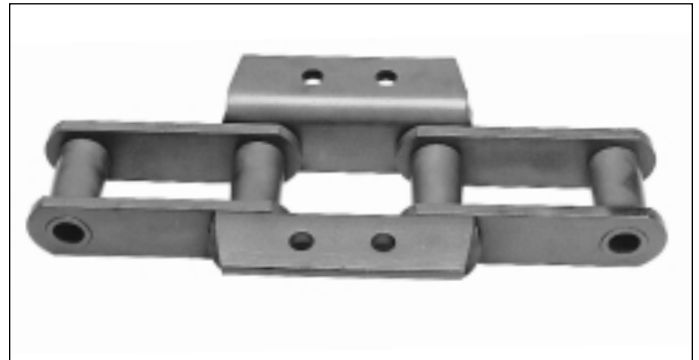
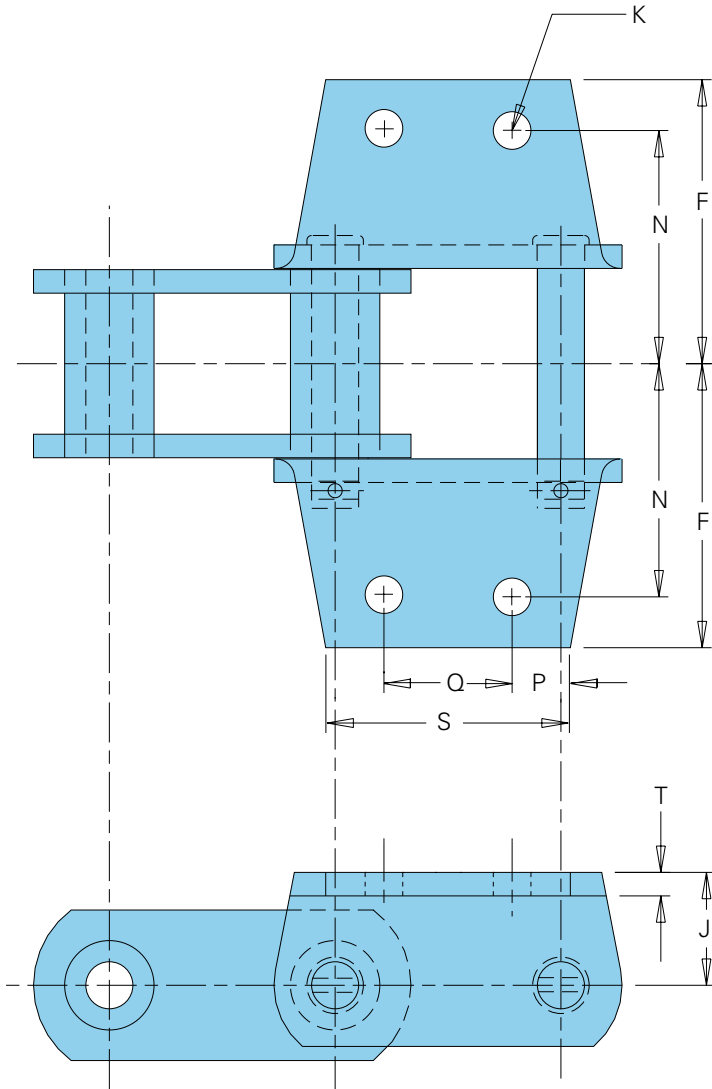

Steel Bushed Attachment Specifications (Continued)

All dimensions are in inches unless otherwise indicated.

Attach. Number	Chain Number	N	M	R	F	L	Q	S	P	Bolt Dia. K	J	T	V	Approx. Weight (lbs./ft.)
K-24	4856	3.63			4.75		2.50	7.25	1.75	.63	1.88	.50		27.5

Indicates this chain is normally stocked. All others are made-to-order.

To locate compatible sprockets for your chain, refer to the Product Cross-Reference in Section D.

Note: Dimensions are subject to change. Contact Union Chain to obtain certified prints for design and construction.

K-3 Attachment

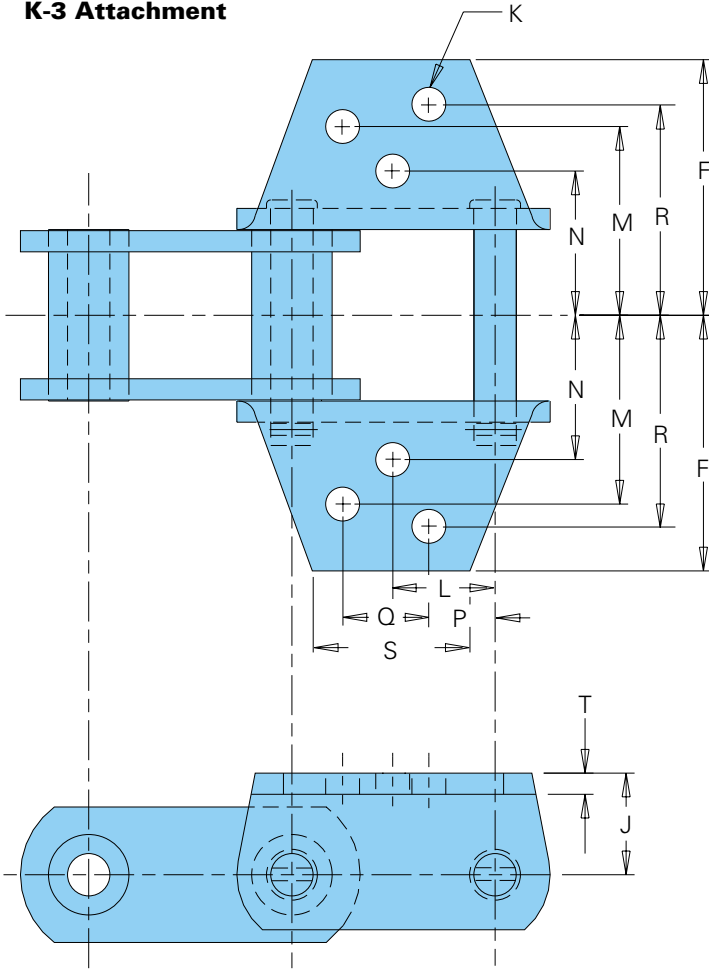

K-35 Attachment

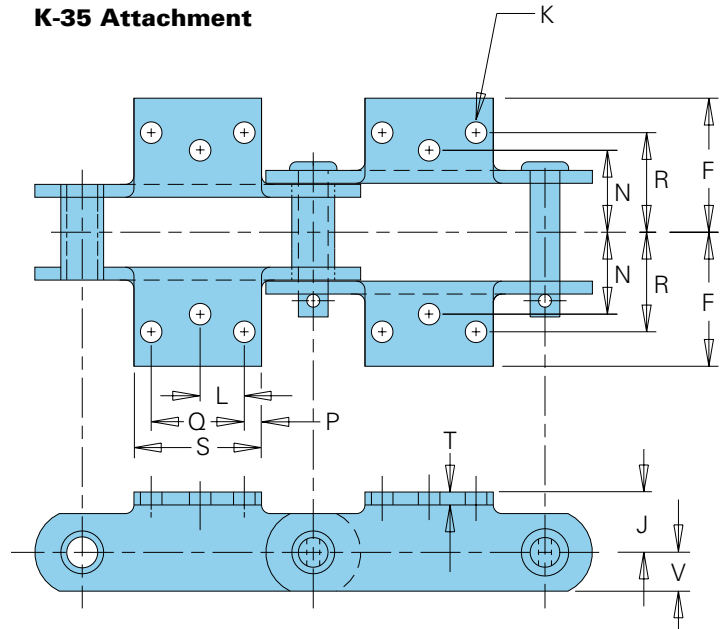

Steel Bushed Attachment Specifications (Continued)

All dimensions are in inches unless otherwise indicated.

Attach. Number	Chain Number	N	M	R	F	L	Q	S	P	Bolt Dia.	K	J	T	V	Approx. Weight (lbs./ft.)
K-3	150X	3.75		5.75	6.53	3.02	2.75	4.25	1.66	.50	1.88	.50			26.9
	4856	3.28	5.47	6.03	6.75	3.00	2.75	4.25	1.63	.50	1.88	.50			27.5
K-35	4856	3.63		6.13	6.75	1.25	2.50	6.44	1.75	.63	1.88	.50	1.25		27.5

To locate compatible sprockets for your chain, refer to the Product Cross-Reference in Section D.

Note: Dimensions are subject to change. Contact Union Chain to obtain certified prints for design and construction.

K-44 and K-443 Attachment

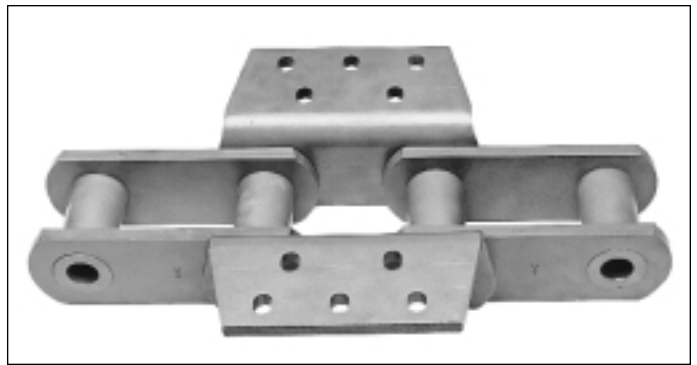
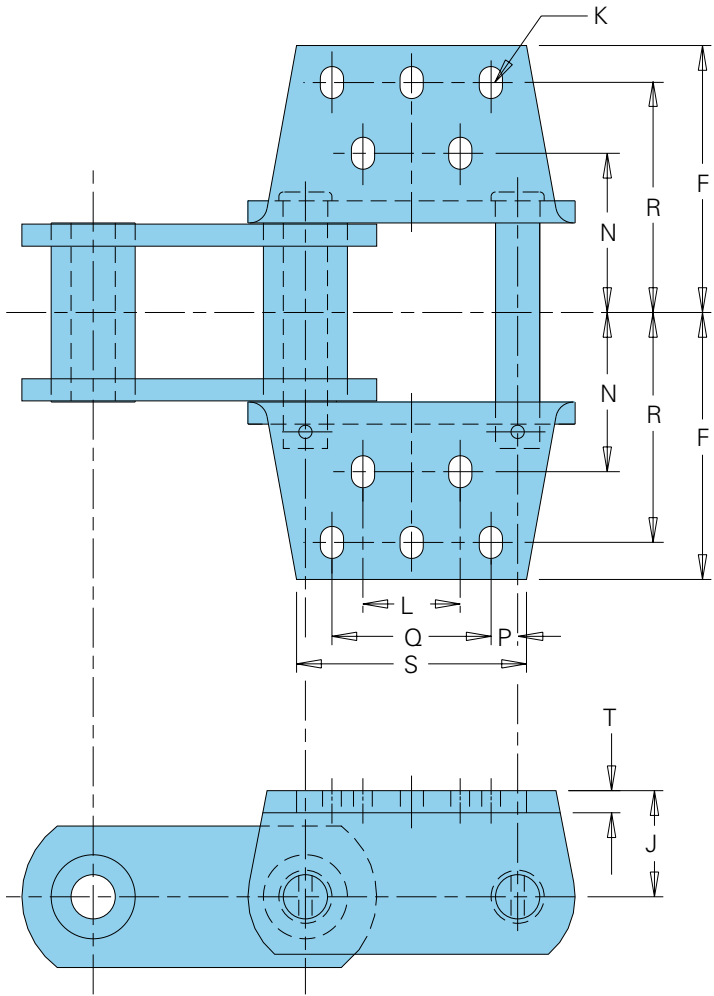

Steel Bushed Attachment Specifications (Continued)

All dimensions are in inches unless otherwise indicated.

Attach. Number	Chain Number	N	M	R	F	L	Q	S	P	Bolt Dia.	K	J	T	V	Approx. Weight (lbs./ft.)
K-44	4857	3.50		6.00	7.25	3.50	3.50	6.56	1.25	.50	2.50	.50			42.0
	4859	4.50		6.50	7.55	2.75	4.50	6.50	.75	.63	3.00	.63			67.0
K-443	4864	4.50		6.50	7.55	3.75	5.50	8.56	.75	.63	3.00	.63			53.0

Indicates this chain is normally stocked. All others are made-to-order.

To locate compatible sprockets for your chain, refer to the Product Cross-Reference in Section D.

Note: Dimensions are subject to change. Contact Union Chain to obtain certified prints for design and construction.